



ROOF MOUNTED  
EQUIPMENT

---

## ***PRODUCT CATALOGUE***

*The Gentili range of roof mounted equipment for light commercial vehicles*



*Gentili have been supporting van users for 40 years, providing our customers with **solutions** which are both innovative and of the highest quality.*

*Our new **roof mounted equipment range** is now even more complete than ever, and our offering includes improved performance and advanced technical design, which means Gentili can deliver products with unparalleled safety records and ease of use for operators.*

***This is our company mission:  
to look above and design  
THE FUTURE.***

  
Ernesto Gentili  
Chairman



## ***G2000 Harrier***

---

**4**



*The G2000 Harrier is our flagship product, having been awarded the coveted and prestigious Adi Design Index award by the Association for Industrial design, a leading Italian design and industry competition, recognised throughout the world for its robust and stringent judging.*

## ***G2000 Maxi***

---

**10**

## ***Eagle roof racks***

---

**18**

# G2000 HARRIER

*Loading and unloading of ladders is easier and more risk-free than ever with the G2000 Harrier, minimising health and safety issues.*

**G2000 HARRIER**  
Created in Italy by Gentili

Gentili have been supplying customers world-wide with the G2000 – a product range which has gained a reputation for its robustness and quality since its launch over 25 years ago, when the first hydraulic ladder rack for LCVs was designed and launched by Gentili.

As an ISO 9001 company, Gentili have a firm commitment to continuous improvement. The G2000 has been constantly updated and our new G2000 Harrier is the most recent dynamic enhancement to the product.

As with all the G2000 products gone before, the Harrier is designed and manufactured in Italy and brings together the wealth of knowledge and time-served experience Gentili have in this market.

The G2000 Harrier is designed to utilise the original roof mounting points. The design improvements bring together quality and style with a touch of Italian flair.

**Why fit anything else?  
Fit the best, fit the original.**



# DESIGNED WITH ERGONOMICS IN MIND

The G2000 Harrier offers a fully assisted ladder mounting and deploying system, therefore becoming the ideal partner for customers looking to equip their vehicles with a safe and easy to use solution.

Due to its design, the G2000 Harrier offers an easy glide, single person operation. All actions are carried out by the operator with their feet on terra firma at all times, being equipped with a precision engineered hydraulic system.

Through 25 years of active use and continual improvement the G2000 Harrier is the most advanced and safest system of its type available.



# MAXIMUM FLEXIBILITY

**The G2000 Harrier** will carry most ladder types available on the market.



The most recent version of the G2000 Harrier has added features, further improving the safe transport of ladders whilst the vehicle is in motion.

The two retaining loops can be repositioned forward and backward independently to keep ladders of differing lengths in the correct and safest position. These retaining loops are coated with

specialised hard-wearing rubber as standard, to generate extra support and to increase the anti-vibration properties of the system and decreasing unnecessary and costly fatigue of the ladders carried.

The front and rear cross members have adjustable impact resistant ABS plastic end stops ensuring the ladders stowed are safe and secure.

G2000 **HARRIER**  
Created in Italy by Gentili





# **MAXI**

**G2000** Created in Italy by Gentili

*The **G2000 Maxi** is the latest addition to our ladder rack range, designed and manufactured at our state of the art facility in Italy. This new product has been designed to securely store two ladders at the same time, whilst still offering the same operational smoothness and safety as our G2000 Harrier single ladder rack.*



Two ladders can be mounted side by side. Two adjustable ladder retainers ensure that the ladders are held in place during transit. Securing straps hold the ladders firmly against the ladder rack at all times.

Sideways movement of the ladders being carried is stopped by the adjustable pair of load stops, fitted front and rear.



*To complement the standard ladder rack range, Gentili have developed our own bespoke ladder rack solution for emergency vehicles where operational ease of use and fast deployment is crucial in such environments.*



## ***G2000 VV.FF.***

*Quality, reliability  
and safety:*

- The ladder rack deployment is assisted by a central damper and 4 gas struts.
- Heavy ladders are stopped from moving forward and backward thanks to two robust retainers made of stainless steel.
- Fast deployment is assured by utilising a long pull-out handle located at the back of the ladder rack.
- A micro switch will trigger a visual and/or sound alarm located in the driver cabin if the ladder rack is not correctly positioned during transit.

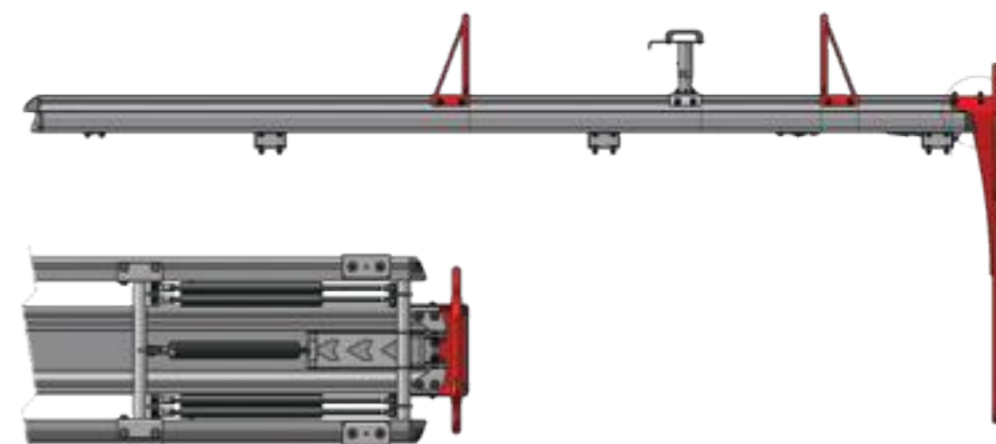



### LIGHTWEIGHT DESIGN

main structural parts made from anodised aluminium.



### UNIVERSAL INSTALLATION

the system can be fitted onto any light commercial vehicle on the market.

### DOUBLE LOCKING

Not one, but two independent securing catches lock the system in place, making it safe when the ladder rack is stowed on the vehicle when it is moving. This feature, invented by Gentili, has been part of the G2000 design from the first prototype made over 20 years ago.



### DURABLE MATERIALS

main parts made from anodised aluminium, offering maximum protection from corrosion and allowing for minimal maintenance. Stainless steel parts offer strength and extended longevity.



### NEW DESIGN

the new design offers improvements to quality and style.



### IMPROVED AERODYNAMICS

New profile parts are designed to be safe, strong and low profile; reducing both wind noise and reducing impact on fuel consumption.



### SECURE

new profile parts are designed to be safe, strong and low profile; reducing both wind noise and reducing impact on fuel consumption.



### TÜV GS CRASH TEST

Gentili take safety seriously – and don't just take our word for it; the G2000 range is TÜV tested and certified and has been crash tested to a 20g force on a vehicle shell. When we say it is safe, we mean it.



# TECHNICAL SPECIFICATIONS

	G2000 Harrier	G2000 MAXI
Type 1 ladder rack	39 Kg	42 Kg
Type 2 ladder rack	41 Kg	48 Kg
Type 3 ladder rack	45 Kg	50 Kg

Safe maximum carrying weight 60 Kg

TÜV GS certified

The 50 km/h (20g) Crash Test has been performed pursuant to ECE R-17

#### G2000 Harrier dimensions

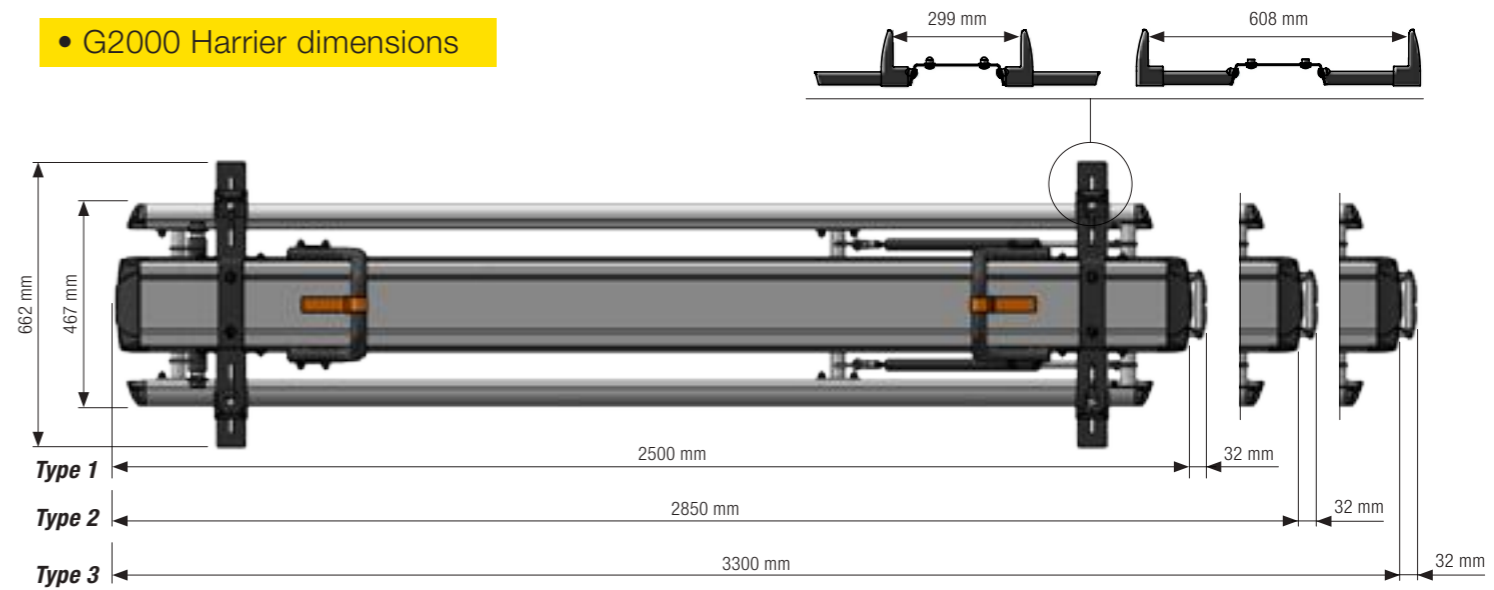

#### G2000 MAXI dimensions

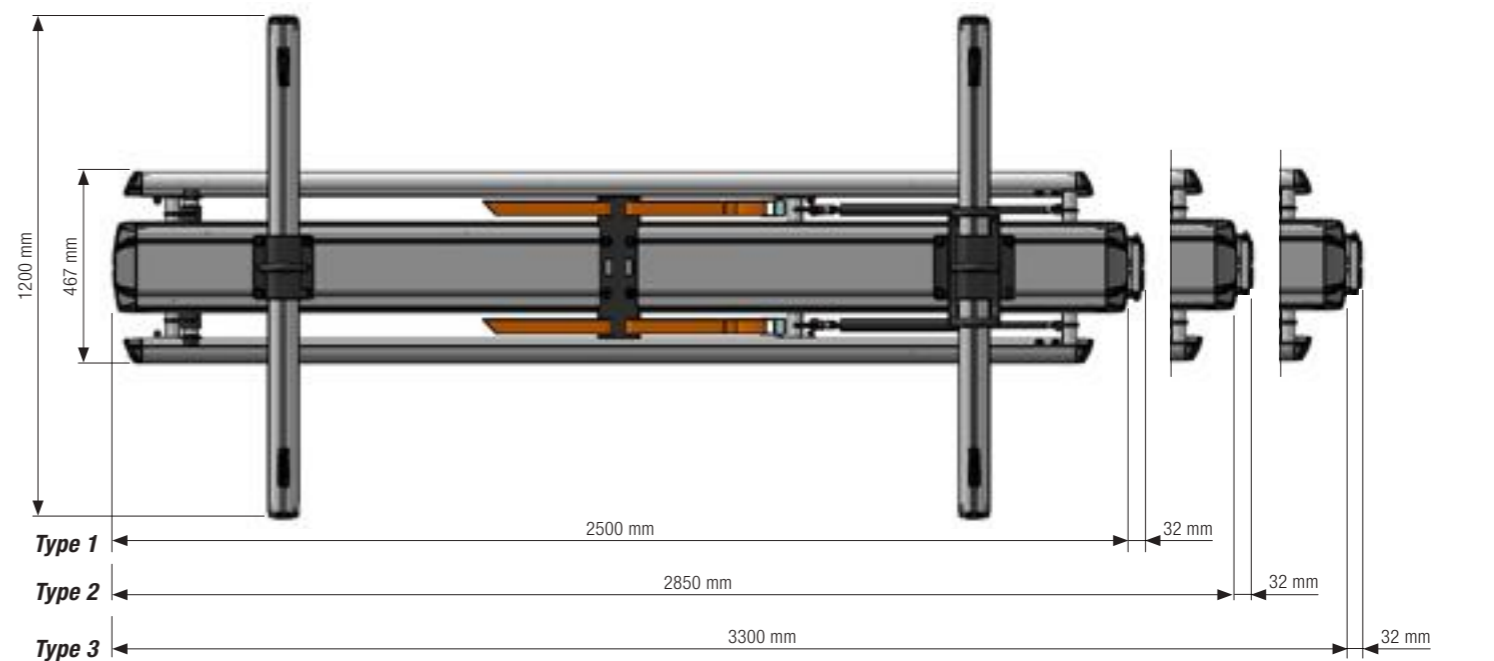

# EAGLE ROOF RACK

*A robust and user-friendly solution offering greater load capacity.*

The Eagle Roof Rack range is a user-friendly system designed with ergonomics in mind. With a rear roller fitted as standard, it allows operators to load and unload items from the roof with ease.

All profiles are made from long lasting, light-weight and anodised aluminium making

them rust free and increasing robustness.

Roof mounting brackets are made from galvanised steel and further protected by a polyester coating.

The Eagle Roof Rack is equipped with an ergonomic, aerodynamic front spoiler reducing wind noise levels and decreasing the impact on fuel consumption.

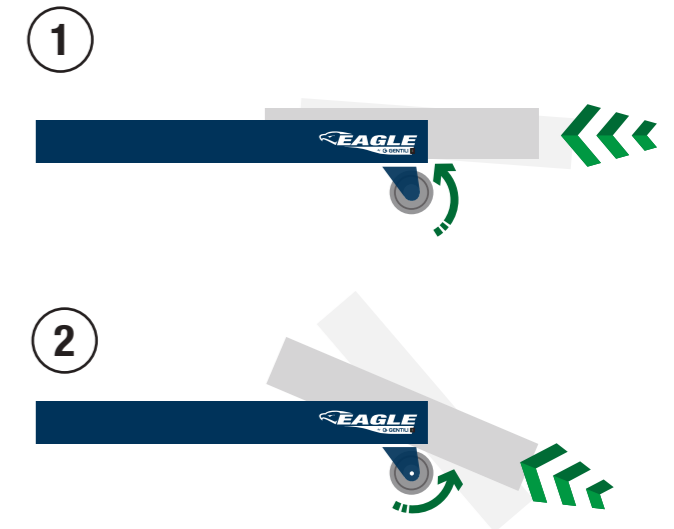

## PIPE TUBES

Available as an accessory

A stainless steel pipe carrier, with an internal retrievable basket for shorter items, is available upon request.



## LADDER LOCK

Available as an accessory



*PATENT No 0000281312*

Ladder lock is an anti-theft device that can be adjusted to suit different ladders which is compatible with our G2000 Harrier.

\* Padlock not supplied





**Gentili Technology Equipment**  
Via Balitrona, 12  
47042 Cesenatico (FC) ITALY  
T. +39 0547 311206 F. +39 0547 311636  
gentili@flligentili.com

---

[www.flligentili.com](http://www.flligentili.com)